

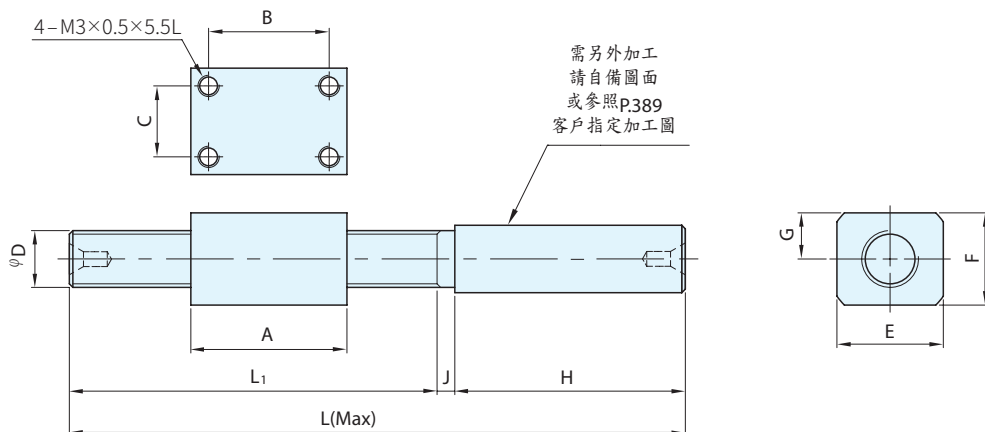

TYPE	精密度等級	螺桿軸		螺帽	
		材質	硬度	材質	硬度
TPOH	C3 C5	S55C	中週波淬火 58~62HRC	SCM415H	浸碳淬火 58~62HRC



品號								A	B	C	E	F	G	H
TYPE	桿徑 D	導程	螺桿牙長 L ₁ (mm)	螺桿總長 L(mm)	螺紋方向	螺帽方向	精度等級 (研磨級)							
TPOH	6	1	L-(H+J)	(H+J)+A+20~170	右旋(R)	正向	C3	20	15	8	13	15	6.5	40
							C5							
		C5												
	8	1	L-(H+J)	(H+J)+A+20~225			C3	22	17	10	15	13	6.5	40
							C5							
		C3												
	4	L-(H+J)	(H+J)+A+20~300	C3	22	17	10	15	13	6.5	40			
				C5										
4	L-(H+J)	(H+J)+A+20~340	C3	22	17	10	15	13	6.5	50				
			C5											

品號								J	鋼珠直徑	動態負載 Ca(N)	靜態負載 Co(N)
TYPE	桿徑 D	導程	螺桿牙長 L ₁ (mm)	螺桿總長 L(mm)	螺紋方向	螺帽方向	精度等級 (研磨級)				
TPOH	6	1	L-(H+J)	(H+J)+A+20~170	右旋(R)	正向	C3	3	0.8	750	1330
							C5				
		C5									
	8	1	L-(H+J)	(H+J)+A+20~225			C3	3		1700	3200
							C5				
		C3									
	2	L-(H+J)	(H+J)+A+20~300	C3	3	1700	3200				
				C5							
4	L-(H+J)	(H+J)+A+20~340	C3	5	2400	3500					
			C5								

Ps. 備註

- L₁可指定長度(規格之外的訂製品)
- 安裝部客戶可自行加工或指定要加工尺寸
- 此圖未依比例標註

訂貨說明：

交期：請洽詢

